



Acrylonitrile

Safe Storage and Handling Guide

Table of Contents

Introduction	1.0
Physical, chemical and thermodynamic properties	2.0
Storage	3.0
Transfer and transport	4.0
Fire safety	5.0
Occupational safety and health	6.0
Medical response and first aid	7.0
Emergency response and environmental protection	8.0

Section 1: Introduction

This booklet was prepared for individuals who handle or may come in contact with Acrylonitrile. It is a compilation of practical, understandable information designed to guide the reader in responsible handling of Acrylonitrile, and to answer commonly raised questions about Acrylonitrile safety. Before handling, always consult a current Material Safety Data Sheet (MSDS), available from INEOS, for information on the chemical. For more complete or detailed information, call the following numbers in the U.S.:

Emergency Notification Number	877-856-3682
Non-Emergency Information Numer	866-363-2454

Information contained in this booklet is not intended to replace any legal requirements for Acrylonitrile handling and storage. Supplemental or more detailed specifications may be necessary for individual application of this material. Information for this booklet was gathered from a selection of widely-recognized chemical industry publications. INEOS makes no representation as to the accuracy of applicability of such information in any specific circumstance.

About the Chemical

Acrylonitrile is a clear, colorless liquid with a slightly pungent odor. It is also a hazardous chemical substance and regulated as such throughout most of the world. However, its hazards and properties are well understood. When appropriate safety procedures are in place, and employees follow those procedures, no excessive danger from the chemical exists. It is essential, however, that employees and affected individuals remain aware and informed. Some of the primary hazards include reactivity, polymerization, fire and toxicity.

- Acrylonitrile is reactive with, and must be kept away from, strong oxidizers, especially bromine. Use extreme care to keep Acrylonitrile away from strong bases, strong acids, copper, copper alloys, ammonia and amines. Contact with these chemicals can cause a chemical reaction resulting in a fire or explosion. Chemical compatibility should also be determined before Acrylonitrile comes in contact with any other chemical.

- Since pure Acrylonitrile may self-polymerize, causing rapid build-up of pressure and resulting in an explosion hazard, Innovene adds inhibitor prior to shipment. This additive inhibits self-polymerization, but does not eliminate all possibility of polymerization.
- Fires involving Acrylonitrile can release toxic gases such as hydrogen cyanide, oxides of nitrogen or carbon monoxide. Its vapors can easily form explosive mixtures in air. Since these vapors are heavier than air, they can also travel along the ground and be ignited by open flames or sparks which are some distance from the site of release.
- The vapors of Acrylonitrile, if inhaled at certain concentrations, can produce serious acute (short-term) toxicity, including loss of consciousness or death. The duration of exposure is also a factor, as is the contact of Acrylonitrile liquid or vapor with the skin. However, if administered effectively, commercially available antidotes can preclude serious harm. Additionally, long term exposure to Acrylonitrile has been shown to cause cancer in laboratory animals.

About the Company

INEOS is the world's largest producer and marketer of Acrylonitrile, a component, or "chemical intermediate," used in the manufacture of acrylic fibers, plastics, synthetic rubber and many other products. The one-step, fluid bed Acrylonitrile manufacturing process was developed by scientists of The Standard Oil Company (Sohio), one of INEOS's predecessors in the U.S. in the 1950s. Today, over 95 percent of the world's Acrylonitrile is manufactured using INEOS's exclusive technology. INEOS offices are located in the Houston, Texas area with research facilities located near Chicago, Illinois.

Section 2: Physical, Chemical and Thermodynamic Properties

Acrylonitrile is a clear, colorless liquid with a slightly pungent odor. The international designation for Acrylonitrile is CAS No. 107-13-1, assigned by the Chemical Abstracts Service. The chemical structure of Acrylonitrile is: $\text{CH}_2=\text{CH}-\text{CN}$

Amoxidation Process

Acrylonitrile is manufactured by combining propylene, ammonia, and air in a process called amoxidation. During amoxidation, propylene, ammonia and air are fed through a catalyst at a high temperature. The vessel containing the chemical reaction is called a fluid bed reactor, where the powdered catalyst moves fluid-like throughout the reactor. This provides a large catalyst surface area for maximum exposure to the reactants.

Useful by-products, or co-products, from the amoxidation reaction include Acetonitrile (CH_3CN), which is used as an industrial and laboratory solvent in the production of insulin and antibiotics, and as a raw material in the production of naturally-occurring pesticides. Another coproduct, hydrogen cyanide (HCN), is used in the manufacture of polyamides, methyl methacrylate, amino acids, chelating agents and other industrial chemicals.

Physical Properties

The physical properties of Acrylonitrile determine its behavior under normal use conditions. Important physical property data are listed in Table 2.1. For information on product specifications, please contact your INEOS representative or consult your supply contract.

Table 2.1 Acrylonitrile process

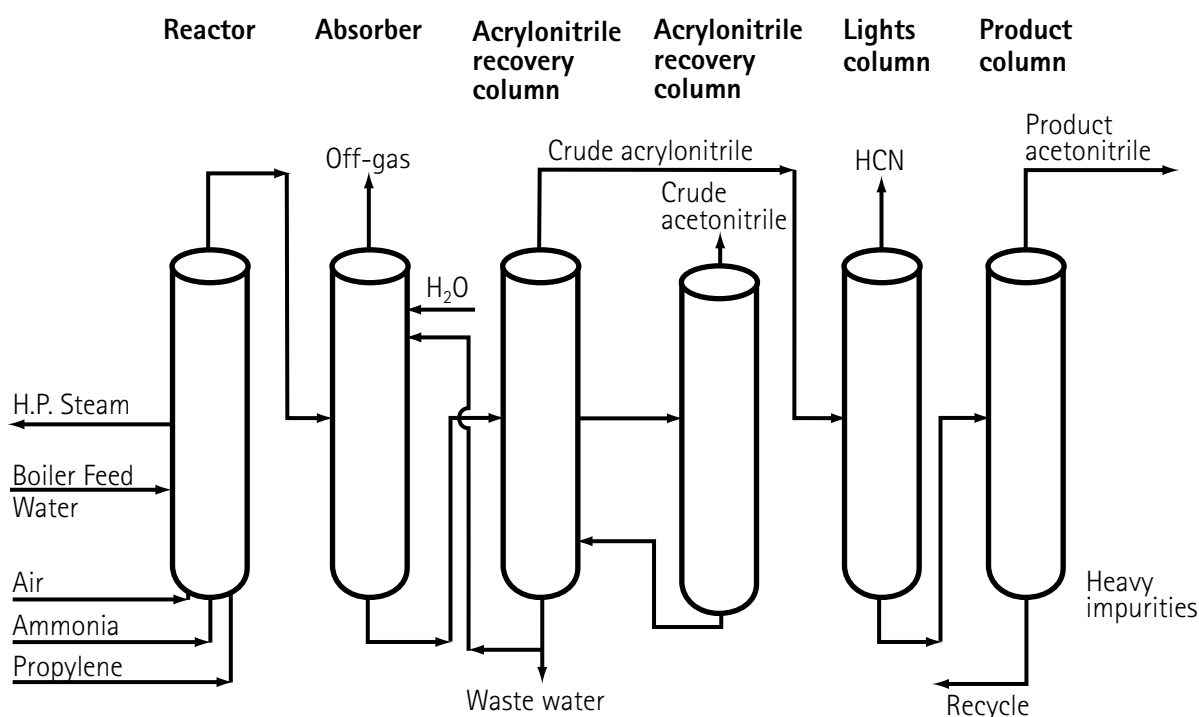
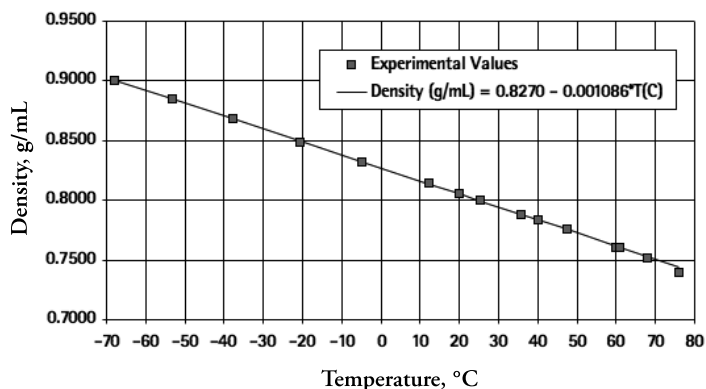

Table 2.1 Physical properties of Acrylonitrile

Property	Value/Units	Comments	Reference
Molecular weight	53.06 g/mole		
Density	0.806 g/mL	at 20°C – see Figure 2.2	4
Melting point	-83.55°C		8
Boiling point	77.30°C	at 760 mm Hg	4
Refractive index n_D^{25}	1.3888	589 nm, at 25°C	1
Solubility in water	7.30 weight %	at 20°C – see Figure 2.5	4
Solubility of water in Acrylonitrile	3.08 weight %	at 20°C	4
Viscosity	0.34 centipoise	at 25.0°C	1
Dielectric constant	38	at 33.4 MHz	4
Dipole moment	3.88 Debye	neat, vapor	5,9
Vapor density	1.83	theoretical; air = 1	3
Critical pressure	2.6524 x 10 ⁴ mm Hg		1
Critical temperature	245.8°C		1
Critical volume	3.790 mL/g		2
Surface tension	27.76 dynes/cm	at 15.1°C	7
	27.53 dynes/cm	at 17.8°C	
	24.80 dynes/cm	at 40.6°C	
Ionization potential	10.75 eV	by electron impact	6
Heat of combustion (liq)	-420.8 kcal/mole		1
Flammability limits in air			
Lower	3.0 volume %	at 25°C	12
Upper	17.0 volume %	at 25°C	
Free energy of formation, $\Delta G_{f,g}^\circ$	46.7 kcal/mole	at 25°C	3
Enthalpy of formation, $\Delta H_{f,g}^\circ$	43.0 kcal/mole	at 25°C	10
Enthalpy of formation, $\Delta H_{f,l}^\circ$	35.16 kcal/mole	at 25°C	10
Enthalpy of vaporization, $\Delta H_{f,vap}^\circ$	7.8 kcal/mole	at 25°C	1
Heat of polymerization	17.3 ± 0.5 kcal/mole		11
Molar heat capacity, liquid	26.53 cal/mole •°K		4
Molar heat capacity, vapor	15.3 cal/mole •°K	50°C, 1 atm	3
Molar heat of fusion	1.58 kcal/mole		3
Entropy, gas	65.5 kcal/mole •°K	at 25°C, 1 atm	3
Autoignition temperature	481°C	in air	1
Flash point	0°C	tag. open cup	2
Thermal conductivity	397 cal/cm sec °C	at 23°C – see Figure 2.7	17

Figure 2.2 illustrates how the density, or specific gravity, of Acrylonitrile varies with temperature.

Figure 2.2: Acrylonitrile liquid density



Source: Reference 14

Figure 2.3 summarizes the variation of the vapor pressure of Acrylonitrile with temperature. Density and vapor pressure are important properties in efficient distillation of Acrylonitrile.

Figure 2.3: Acrylonitrile vapor pressure

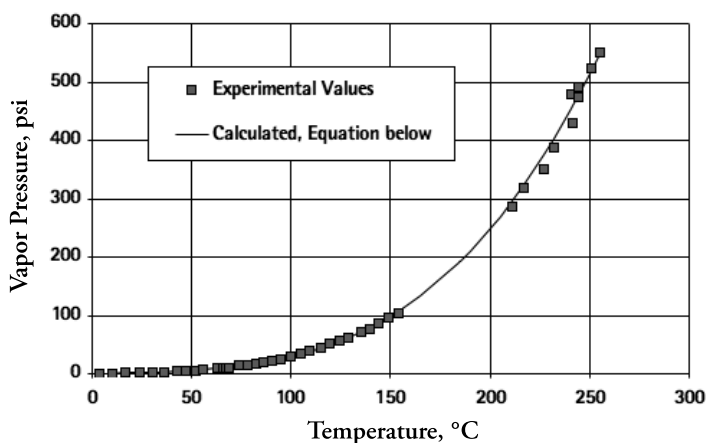

Calculated vapor pressure:
 $P(\text{Pa}) = \exp(47.6009361 - 5125.6810222/T(\text{K}) - 3.6823744 \cdot \ln T + 1.20848E-6 \cdot T^2)$

Source: Reference 15

Chemical Properties

The presence of both the olefinic (carbon-carbon double bond) group and the nitrile (cyano) group in Acrylonitrile gives the molecule its unique and varied reactivity. This reactivity leads to the great versatility of Acrylonitrile as a raw material. The olefinic group can undergo polymerization and co-polymerization, hydrogenation, oxidation, addition and cyclization. The nitrile group can undergo hydrogenation, hydrolysis, hydration, esterification, cyclization and reduction.

Product Stability

Acrylonitrile is stabilized against polymerization in storage by adding water (0.2 to 0.5 weight %) and the inhibitor methylhydroquinone (MeHQ, 35-45 ppm). Keeping the pH within the specified range and controlling the concentrations of iron, copper and peroxides also contribute to product stability.

Thermodynamic Properties

Table 2.1 lists thermodynamic properties of Acrylonitrile. Thermodynamics play an important role in storage, handling, transport and use.

Flammability

Acrylonitrile is flammable because it is a volatile organic chemical. Properties of flammability are defined by:

- flash point – the temperature at which the vapor above a liquid is ignitable when mixed with air.
- autoignition temperature – the temperature above which a vapor mixture and air can ignite without a spark or other source of ignition.
- heat of combustion – the measure of the amount of heat given off when Acrylonitrile burns completely, forming nitrogen, carbon dioxide and water.

The values for above properties are listed in Table 2.1.

Vapor mixtures of Acrylonitrile and air containing between 3 and 17 percent Acrylonitrile are potentially flammable (see “flammability limits” in Table 2.1) This flammability envelope is a function of temperature, pressure and the concentration of oxygen in the vapor. A representative graph showing the flammability envelope for Acrylonitrile at 32°C is shown in Figure 2.4.

Figure 2.4: Flammability limits of acrylonitrile in oxygen-nitrogen mixtures. Temperature = 32°C

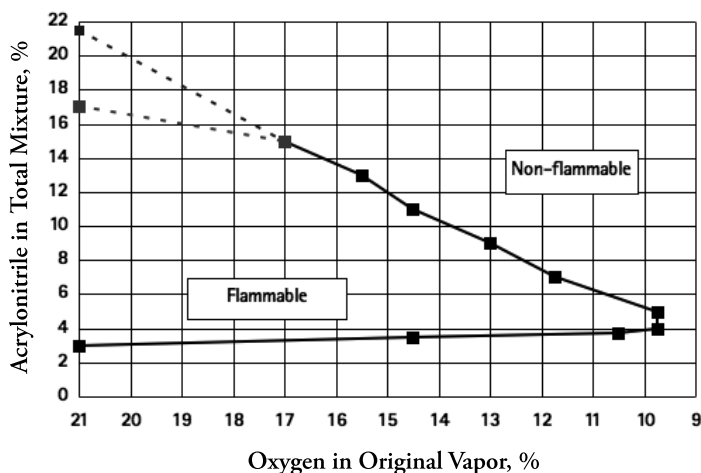

Source: References 2 and 12

Vapor combinations of Acrylonitrile and air which fall inside the “nose-shaped” region on the graph are potentially flammable. Vapors outside the nose are not flammable. These concentrations should be consulted during the design of equipment and operating conditions. (For example, “nitrogen blanketing” – a procedure designed to prevent flammable vapor mixtures during handling, transfer and storage of Acrylonitrile. See Section 3.)

Solubility

Acrylonitrile is miscible with most organic solvents, including acetone, acetonitrile, benzene, carbon tetrachloride, diethyl ether, ethyl alcohol, ethyl acetate, methanol, petroleum ether, toluene, xylene and some kerosenes.

Acrylonitrile and water are partly soluble in each other. The solubilities of Acrylonitrile in water and water in Acrylonitrile as a function of temperature are summarized in Figure 2.5. Vapor pressures of Acrylonitrile above the surface of its solutions in water (at 25°C and 40°C) are shown in Figure 2.6. Thermal conductivity of liquid Acrylonitrile is shown in Figure 2.7.

Figure 2.5: Solubilities of acrylonitrile and water

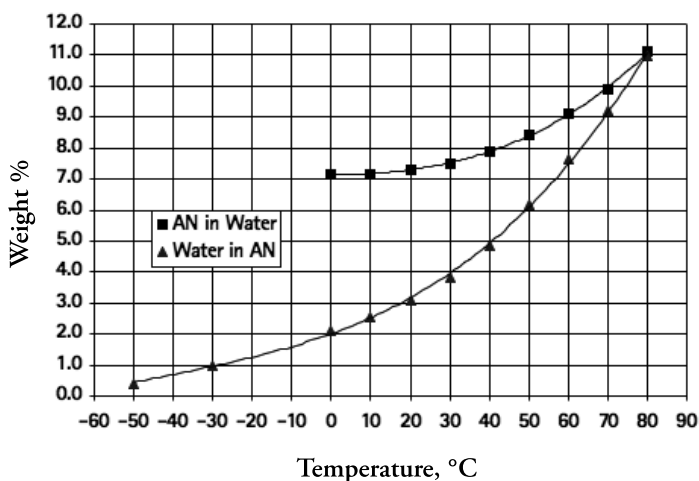

Source: Reference 4

Figure 2.6: Vapor pressure of acrylonitrile over aqueous solutions

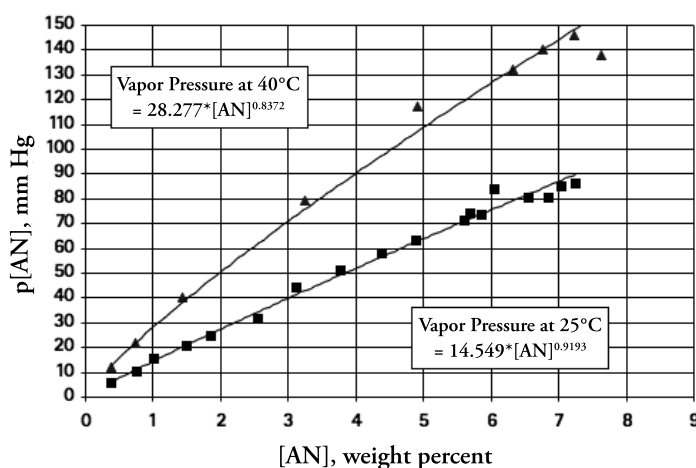

Source: Reference 16

Figure 2.7: Thermal conductivity of liquid acrylonitrile

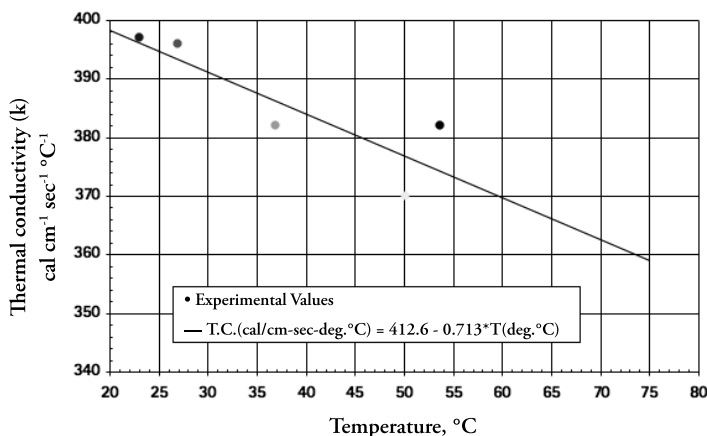

Source: Reference 17

The solubility of oxygen in Acrylonitrile is important for proper storage and handling because dissolved oxygen is required for effective inhibition of polymerization by the inhibitor MEHQ (see Section 3.) Figure 2.8 shows the solubility of oxygen in Acrylonitrile, expressed in parts per million, at several temperatures when Acrylonitrile is in equilibrium with air under a normal pressure of 1 atmosphere.

Figure 2.8: Solubility of oxygen in acrylonitrile in equilibrium with air, 1 atmosphere pressure

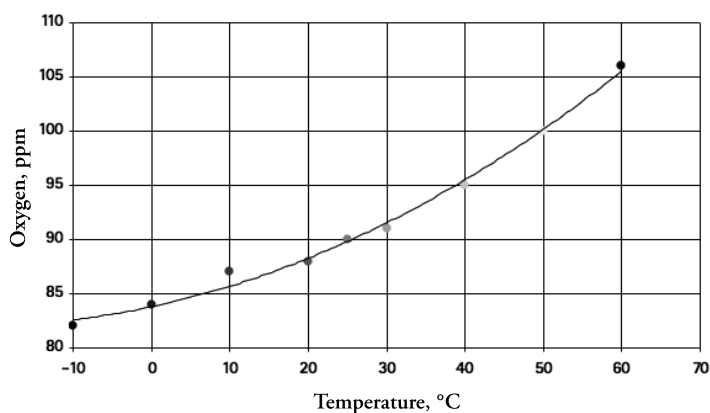

Source: INEOS Nitriles

Acrylonitrile combined with one of several organic compounds or with water can form azeotropes – constant boiling mixtures. Information on certain Acrylonitrile azeotropes is summarized in Table 2.2.

Table 2.2: Binary azeotropes of Acrylonitrile

Azeotrope	Boiling Point, °C	Acrylonitrile concentration, weight, %
Water	71	88
Benzene	73.3	47
Methanol	61.4	38.7
Isopropyl Alcohol	71.7	56
Carbon Tetrachloride	66.2	21
Tetrachlorosilane	51.2	11
Chlorotrimethylsilane	57	7

Source Reference 13.

References

The references listed below provide the original descriptions of experimental methods for determining the physical and thermodynamic properties of Acrylonitrile and include summary articles describing the properties, manufacture, use and chemistry of Acrylonitrile.

Reviews and General Articles

1. American Cyanamid Co., *The Chemistry of Acrylonitrile*, 1951, pp. 11-19.
2. Monsanto Chem. Int. Co., "*Acrylonitrile Handling and Storage*," Pub. No. 162, Jan. 1982.
3. Brazdil, J.F. "Acrylonitrile," in *Kirk-Othmer Encyclopedia of Chemical Technology*, 4th Ed., Vol. 1, Wiley-Interscience, 1991, pp. 352-369.
4. Davis, H.S., Wiedeman, O.F. *Ind. Eng. Chem.*, 1945, 37, 482-485.

Articles on Specific Physical, Chemical and Thermodynamic Properties

5. Hurdis, E.C., Smith, C.D. *J. Amer. Chem. Soc.*, 1943, 65, 89-96.
6. Morrison, J.D., Nicholson, A.J.C. *J. Chem. Phys.*, 1952, 20, 1021-1023.
7. Vogel, A.I., Cresswell, W.T., Jeffery, C.H., Leicester, J. *J. Chem. Soc.*, 1952, 514-540.
8. Witschonke, C.R. *Anal. Chem.*, 1954, 26, 562-564.
9. Wilcox, W.S., Goldstein, J.H., Simmons, J.W. *J. Phys. Chem.*, 1954, 22, 516-518.
10. Hall, H.K., Jr., Baldt, J.H. *J. Amer. Chem. Soc.*, 1971, 93, 140-145.
11. Tong, H.K.J., Kengon, W.O. *J. Amer. Chem. Soc.*, 7, 69, 2245-2246.
12. "*Limits of Flammability of Gases and Vapors*," *Bulletin 503*, U.S. Bureau of Mines, 1952.
13. Horsley, *Analyt. Chem.*, 1947, 19, 509-603.
14. Naziev, Y.M., Guseinov, S.O., Shakhmuradov, S.G. *Proc. Symp. Thermophys. Prop.*, 1982, 8th (1), 227-231.
15. Daubert, T.E., Hutchinson, G. *AIChE Symp. Ser.*, 1990, 86(279), 93-114.
16. Funk, C.E., Jr. *Ind. Eng. Chem.*, 1951, 43, 1153-1155.
17. Pagerey, P.F., St. Clair, C.R., Sibbitt, W.L. *Transactions of the ASME*, 1956, 78, 1169-1173.

Section 3: Storage

Each bulk storage facility requires individual consideration based on the user's specific requirements, the nature of the site and the impact on any existing facilities in the vicinity.

Acrylonitrile is commonly delivered to storage in bulk by truck, rail car, pipeline, barge or ship. It is also delivered in drums. When designing a storage facility consider the optimum storage capacity – keeping in mind the expected delivery vehicle and quantity, and estimated future capacity requirements. Avoid storage times in excess of six months to minimize the potential for degradation of Acrylonitrile quality. See “prevention of polymerization” (below) for maintenance of polymerization inhibitors during long-term storage.

Acrylonitrile storage and handling is subject to regulations and controls in many parts of the world. Requirements of local and national regulations should be determined at the earliest point in the design of a storage facility.

Storage Hazards

In addition to worker exposure, the primary potential hazards of Acrylonitrile handling are polymerization and explosion or flammability. Both reactions are exothermic – a reaction accompanied by heat. The heat of exothermic reactions is their primary hazard. The heat of polymerization of Acrylonitrile is 17.3 kcal/gram-mole. The heat of combustion of Acrylonitrile is 420.8 kcal/gram mole. (See also Section 2, Table 2.1.)

Prevention of Polymerization

A useful means of preventing unwanted polymerization in storage is to confirm that product specifications are met. Product specifications insure that substances which can initiate polymerization are not present in dangerous amounts. Acrylonitrile is incompatible with a variety of chemicals and conditions which can lead to violent reactions, usually initiation of rapid exothermic polymerization. Although extremely pure Acrylonitrile is stable at temperatures of 100°C or more, in the presence of even trace amounts of these incompatible materials polymerization can be rapid and unpredictable. These chemicals and conditions are shown in Table 3.1.

Table 3.1: Incompatibilities with Acrylonitrile

Chemicals
Bromine
Ammonia
Amines
Copper and copper alloys
Strong Acids
Strong bases (e.g. potassium hydroxide, sodium hydroxide)
Peroxides or other free radical initiators
Conditions
Complete absence of oxygen
Exposure to ultraviolet light
Heat
Pressure

The potential for unwanted polymerization is minimized by the inhibitor system: water (0.2 to 0.5 weight percent) and MEHQ (35 to 45 ppm) (see Section 2.) Each compound interrupts potential polymerization reactions by consuming trace reactive intermediates before polymerization begins or becomes uncontrolled.

Water inhibits ionic polymerization by trapping basic or acidic intermediates. MEHQ inhibits free radical polymerization by trapping free radical intermediates. MEHQ requires dissolved oxygen for proper inhibition of polymerization. Under most conditions, Acrylonitrile will contain sufficient quantities of dissolved oxygen from exposure to air during manufacturing, handling and storage.

Prevention of Flammability

Nitrogen blanketing substantially reduces the potential for flammability of vapors above the surface of liquid Acrylonitrile. During nitrogen blanketing, oxygen is purged from the vapor space in the vessel or tank. The oxygen level should be purged to below 8 percent. Although the MEHQ and water inhibitor system will remain effective well below 8 percent oxygen in the vapor space, complete exclusion of oxygen is discouraged because the inhibitor system becomes ineffective when oxygen is absent. Nitrogen blanketing may be accomplished through various systems.

Maintaining Stability in Storage

The most important first step in safe handling and storing of Acrylonitrile is to follow good storage practices. Uninhibited Acrylonitrile should never be stored or transported, and Acrylonitrile should be inhibited with the proper levels of water and MEHQ (see above). Exposure to the chemicals and conditions known to be incompatible with Acrylonitrile (see Table 3.1) should be scrupulously avoided. Sources of heat should also be avoided, including pumping Acrylonitrile against a closed valve to unusually high pressures or for unusually long periods of time. Storage of Acrylonitrile should be limited to less than 6 months.

Acrylonitrile should be monitored for a series of indications that unwanted polymerization may be occurring. Haziness in a sample of stored Acrylonitrile can indicate formation of poly (acrylonitrile), which is insoluble in the monomer. The pH, measured as a 5 percent aqueous solution by weight, should be watched. If the pH is in the basic range (above pH 7.3) ionic polymerization may be occurring, and this polymerization can be accompanied by the generation of ammonia. The MEHQ inhibitor level should be monitored to assure that inhibitor is not being consumed. Finally, a temperature rise in the monomer can indicate unwanted reaction.

If any of the above conditions is observed, the following steps should be taken IMMEDIATELY:

1. If the pH of a 5 percent aqueous solution of Acrylonitrile is above 7.5, the Acrylonitrile should be acidified. It has been recommended to acidify by adding a 1:2 acetic acid: Acrylonitrile mixture and mixing thoroughly.
2. A 4 percent solution of hydroquinone, HQ, in Acrylonitrile should be added with thorough mixing to bring the HQ concentration to about 100 ppm. HQ, while it discolors Acrylonitrile readily, is reported to be a more effective inhibitor than MEHQ.
3. Water can be added to inhibit ionic polymerization and to dilute the Acrylonitrile monomer.
4. External cooling may be accomplished by spraying water on the container or tank. However, this may not be effective if the container is insulated.
5. Pressure buildup can be alleviated by venting the tank through an adequate pressure relief-vent system. Assure that Acrylonitrile is efficiently condensed and that the condensed Acrylonitrile is properly inhibited.

Once the Acrylonitrile is effectively inhibited against further polymerization, it should be removed immediately for repurification or disposal. The Acrylonitrile should be continually monitored to check for any renewed signs of polymerization.

Tank Location

The arrangement of tanks and equipment should take into account access for normal operation and maintenance, emergency response teams and equipment, as well as emergency evacuation. Storage facility personnel should also be familiar with locally available fire fighting capabilities.

Tank “farms” housing other chemicals must be designed to keep all chemicals segregated – especially in the event of a spill or fire. Products which chemically react with Acrylonitrile should not be stored in the vicinity.

Storage tanks should be constructed at ground level and in open air. This placement will allow easy detection of unwanted vapor emissions and will aid natural ventilation in dispersing vapors.

Tanks must be located away from a potential source of ignition, including the possibility of radiation from a fire in an adjacent area.

Consult local regulations to determine and design adequate space between tanks.

In the U.S. all tanks should be surrounded by a dike wall capable of containing 110 percent of the largest tank within the dike. The walls and floor of the dike should be impervious to liquid and designed to withstand a full hydrostatic head. Suitable construction materials include compacted clay, concrete, synthetic sheeting, or geotextiles. In many locations around the world, selection of these material may be subject to applicable regulatory requirements.

Dike walls should not be higher than 5 feet in order to insure adequate ventilation of the area, ready access for fire fighting, and easy escape during an emergency.

Intermediate dike walls are recommended to segregate tanks into groups and to minimize the impact of an accidental spill on adjacent areas.

The floor of the diked area should slope away from tanks to prevent minor spills from collecting and remaining underneath a tank.

Drainage of surface water and rain runoff should be provided for, preferably by air-driven pump or an electric pump with a flameproof motor. Diked areas with drains should have valves located outside the dike walls. These valves should be marked with a precautionary warning and should remain shut, except when run-off is being removed.

Tank Design

The tank should be designed in accordance with an appropriate, recognized standard of good engineering. Stainless steel or carbon steel are recommended for tank construction.

Carbon steel tanks are usually cleaned either by chemical or physical means before initial use to remove rust. If the tank is cleaned by chemical means, further cleaning with water, according to an accepted procedure, is mandatory in order to prevent a potential chemical reaction.

Copper materials should not be used in the construction of an Acrylonitrile storage tank. Copper can induce polymerization and also discolor Acrylonitrile.

Tank roofs should be fixed, with or without an internal floating roof. Internal floating roofs significantly reduce vapor emissions. These roofs may be constructed of aluminum for weight savings and lower expense. Seals on internal floating roofs may be vapor or liquid mounted double seal. Manufacturer's specifications should be consulted for the proper type of seal – to accommodate individual storage locations and climatic conditions.

Steam cleaning can damage commonly-used floating roof seal materials. Tanks with floating roofs must not be steamed unless the seals are designed to withstand steam cleaning.

Multi-compartment tanks are not recommended because of potential product contamination and possible heating from adjacent compartments.

Where vent scrubbers are used as part of a vapor control system, suitable arrangements should be made for the disposal of vent scrubber water or carbon drums, depending on the system used.

Acrylonitrile storage tanks normally do not require insulation or refrigeration. However, in extremely hot climates, insulation and refrigeration should be considered in tank design. White paint is recommended for the exterior surface to minimize interior temperature increases.

On production units, agitation of storage tanks is recommended for circulation of inhibitors and for product uniformity. Inhibitor is normally added to the product as part of the production process.

A manhole, or "manway," of at least 20" should be provided on all tanks to allow for internal inspection and cleaning. Table 3.2 lists recommended manway sizes based on the diameter of the tank.

Tank diameter	Number and size of manways
0 – 24'	1 manway, 20"
25' – 100'	2 manways, 24" each
101' – 150'	3 manways, 24" each
151' – 250'	4 manways, 24" each

Table 3.2: Recommended manway sizes

Internal pipework should be designed to prevent splash filling.

New tanks should be designed for full draining – sloped to an outlet with no areas where Acrylonitrile might be trapped during draining.

Tank Inspection

Tank inspection should be performed in accordance with API 653 (the American Petroleum Institute's standard for "Tank Inspection, Repair, Alteration, and Reconstruction".) The following guidelines are based on the API recommendations, however, more frequent inspections may be necessary for compliance with local requirements.

External Inspection

- Routine in-service inspections – The external condition of the tank should be monitored by close visual inspection from the ground on a routine basis. The interval of such inspection should be consistent with conditions at the particular site, but should not exceed one month.

- Scheduled inspection – All tanks should be given a formal visual external inspection at least every 5 years, or at the quarter corrosion rate of the shell, whichever is less. Inspections should be performed by an inspector who is qualified in accordance with API 653 Section 4.10.
- In-service ultrasonic thickness measurements of the shell – The extent of such measurements should be determined by the owner/operator. When used, the ultrasonic thickness measurements should be made at intervals not to exceed the following:
 - a – five years after a new tank is commissioned
 - b – at five-year intervals for existing tanks where the corrosion rate is not known
 - c – when the corrosion rate is known, the maximum interval should be 15 years or RCA/2N years, whichever is less. (“RCA” is the “remaining corrosion allowance.” And “N” is the shell corrosion rate in mils per year.)

Internal Inspection

Corrosion rates measured during previous inspections or experience with tanks in similar service should be considered in determining the intervals between internal inspections. Measured or anticipated bottom corrosion rates in relation to the minimum required thickness of tank bottoms should also be considered.

The actual inspection interval should be set to ensure that the bottom plate minimum thicknesses at the next inspection are not less than:

- 0.10 inches for tank bottom/foundation design with no means for detection and containment of a bottom leak, or
- 0.05 inches for a design with the means to provide detection and containment of a bottom leak.

In no case, however, should the interval between inspections exceed 20 years.

When corrosion rates are not known, or when the owner/operator’s experience cannot determine the minimum bottom thickness at the next inspection, the actual bottom thickness should be determined by regular internal inspection(s) for the next 10 years.

Piping

A tank discharge line should be provided which should be a minimum of 2” nominal bore. The line may be taken from the bottom or side of the tank and should be fitted with an isolating valve, as close to the tank wall as possible. In all cases, discharge should be by pump.

Capability for draining the tank should be provided. Drainage should take place from the lowest point in the tank with a suitable isolation valve. The isolation valve should be closed and locked when not in use.

Wherever possible, continuous welding should be used in pipeline construction. Flange joints should be used where pipes are periodically disconnected for maintenance or inspection. Flanges should conform to the American National Standards Institute (ANSI) 150 lb. PTFE envelope gaskets should be used; gaskets of similar non-swelling material are also suitable. Screwed fittings should not be used except with stainless steel components.

Piping should not be located over doorways or windows, or close to possible sources of ignition – to minimize the possibility of accidental damage.

Fixed (stationary), dedicated loading/unloading arms are recommended. Hoses used for loading and unloading should be stainless steel flex hose, Acrylonitrile-resistant lined, or equivalent. Hoses should be frequently inspected for wear or damage, and replaced as necessary.

Tanks should be fitted with a grounding point and connected to a good ground. The resistance to ground at any point of the installation should be less than 10 ohms. This also applies to the grounding point of all discharge equipment, which should be connected to the same ground. If discharge equipment is grounded independently, the ground should have minimal resistance between the discharge equipment and the tank-pipework system.

Pumps

Pumps should be located outside of tank dikes, on an impervious base, in open space. They should not be located in walled-off or confined spaces.

Centrifugal pumps designed to ANSI (American National Standards Institute) standards or an equivalent are normally used for transferring Acrylonitrile to and from storage. The pump mechanical seals can be of either the single, double or tandem seal design. To maintain product quality, both the single and double seals should be self flushing. For added environmental protection, tandem seals with a self flush inboard and a seal water flush outboard seal may be used. Seal face materials should be carbon against silicon carbide or carbon against tungsten carbide. For Acrylonitrile service, the seal gasket elastomer should be silicone rubber.

Plastic pumps should not be used. Pumps should be constructed of either cast steel or stainless steel.

Pumps may be driven pneumatically, hydraulically or electrically. Electric pumps should be flameproof.

Remote control pumps should also have a shut-off button at the pump's delivery point.

Pumping output should not exceed the recommended speed or capacity of the piping system, especially in the discharge pipelines.

Gravitational flow may occur in a centrifugal pump when the pump is stopped. This flow should be anticipated and compensated for.

Valves

Isolating valves may be ball or gate valves with PTFE seats. Angle or globe valves are also acceptable on Acrylonitrile service.

Diaphragm valves should not be used with Acrylonitrile.

Valve bonnet gaskets may be soft iron, spiral wound or equivalent. Valve stem packings should be Garlock 9000 EVSP (or equivalent) graphite packing.

Level and Temperature Measurement

Storage tanks should be provided with a means for determining both the liquid level and tank temperature. Opening a gauge hatch is not recommended where it might involve personal exposure to Acrylonitrile.

Where manual or open measurement is unavoidable, operators must wear suitable protective clothing and respirators to protect against Acrylonitrile exposure. (See Section 6.)

Level indicators should be intrinsically safe for use with Acrylonitrile, based on nationally-accepted standards. High level alarms and automatic feed cut-off controls should be considered for installation in a tank to prevent overfilling.

Sampling and Analytical Techniques

Analysis of representative samples is commonly performed to determine the product quality of Acrylonitrile. Key parameters of quality include appearance, solution pH, color, water and inhibitor content, etc. The following should be observed:

1. Closed systems should be used for drawing product samples. Totally enclosed sampling systems minimize personnel exposures.
2. Clean, dry polypropylene or amber-colored glass bottles should be used for sample collection. Polypropylene bottles should be checked frequently for stress cracks or other signs of wear, and should be replaced when necessary to prevent unexpected leakage. Clear glass should not be used if prolonged exposure to light is expected.
3. To prevent the build up of static electricity during sampling, draw product slowly; ensure that dip pipes, if used, are free from rough edges; and make necessary grounding connections.

Nitrogen Blanketing

Nitrogen blanketing is recommended for keeping the oxygen level at or below 8 percent, for fire protection. (See "Prevention of Flammability" at the beginning of Section 3)

Vapor Control System

A vapor control system should be installed at the facility to control displaced vapors from transport equipment during loading or unloading. Vapors should be kept from release into the atmosphere for the protection of operators and the environment.

A number of different control systems are available and local regulatory requirements may vary. Vapors can be destroyed through incineration; recovered through a refrigeration/condensation process; absorbed through charcoal; processed through a scrubbing system; or vapor balanced to a storage tank.

Proper training of ship or barge and facility personnel is essential for safe operation. Training is essential to reduce the possibility of the following hazards: flame propagation from vessel to shore systems; over or under pressurization; and chemical spillage.

Electrical Considerations

Pumps, tanks, electric motors and all parts of the system must be effectively grounded to prevent the accumulation of static electrical charges.

Working areas, for example, tank stairs, platforms, loading and unloading points, should be adequately illuminated during working hours.

Electrical equipment used in hazardous areas must be non-sparking or otherwise suitable for the area where it will be used. The selection, installation and maintenance of such electrical equipment should be based on an internationally-accepted hazardous area classification scheme. First, determine the area's classification. Next, consult an accepted electric code which lists suitable equipment for use in that area classification.

For instance, the following selection scheme is used in the United States.

The appropriate national or international electric code should be used in conjunction with the area classification methodology for a "heavier-than-air" gas source. See Appendix 3.1 for API (American Petroleum Institute) "Recommended Practice 500" diagrams of tank, rail/truck, and marine area classifications. The National Electric Code is not provided and must be consulted elsewhere.

Appendix 3.1

This appendix contains diagrams of the electrical classification areas for storage tanks, marine applications, and truck and rail. All diagrams in Appendix 3.1 are included courtesy of the American Petroleum Institute; publication #RP 500, Recommended Practice for Classification of Locations for Electrical Installations at Petroleum Facilities. First Edition, June 1, 1991.

Figure A-1a: Volatile oil with heavier-than-air gas source

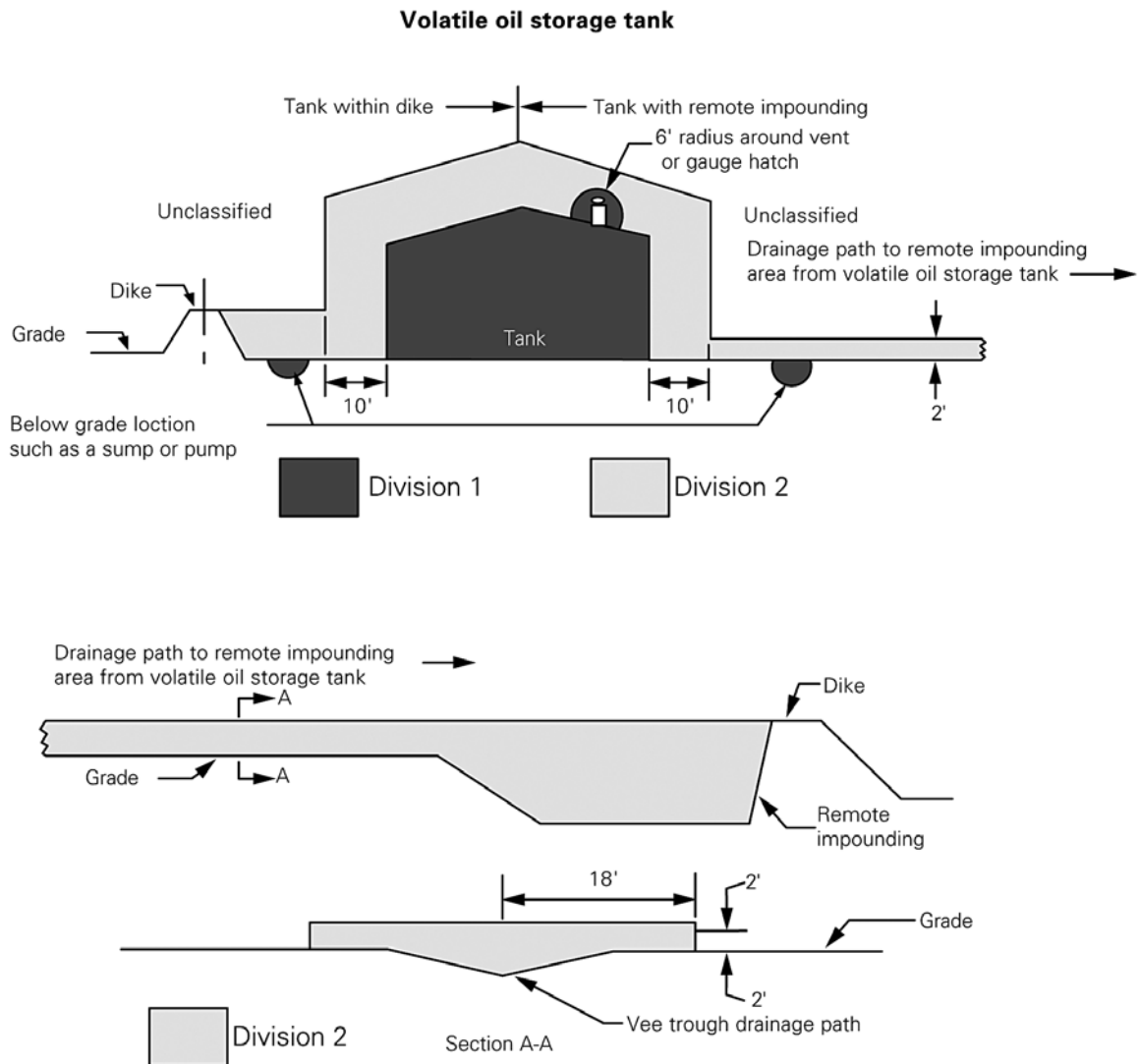

1. For floating-roof tanks, the area above the tank roof and within the shell is classified Division 1.
2. High filling rate or blending operations involving Class 1 liquids may require extending the boundaries of classified areas.
3. Distances given are for typical process areas and oil and gas handling facilities; they must be used with judgement, with consideration given to all factors discussed in the text.

**Figure A-1b: Tank car/tank truck loading and unloading via closed system
Transfer through dome only (NFPA 497A)**

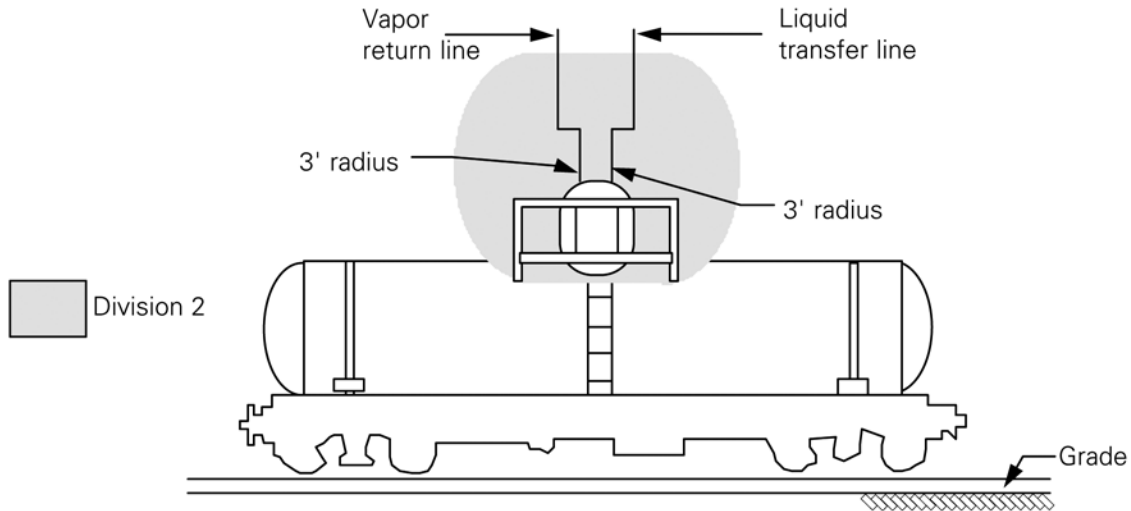

Material: Flammable liquid

Figure A-1c: Refinery marine terminal handling flammable liquids

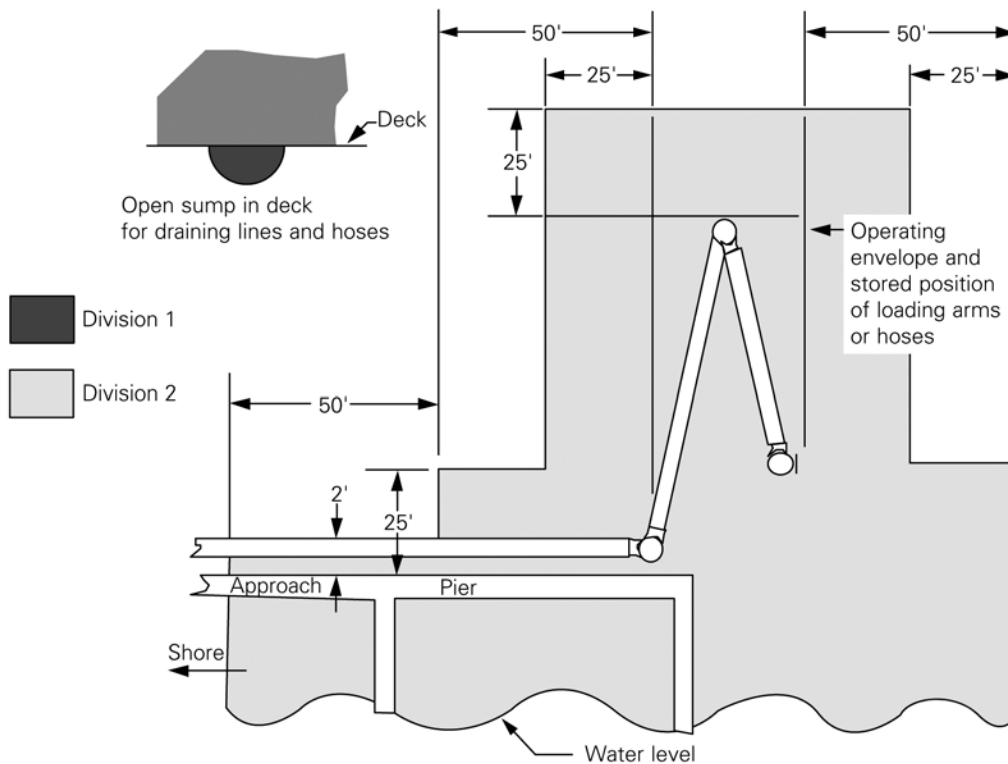

1. The "source of vapor" shall be the operating envelope and stored position of the outboard flange connection of the loading arm (or hose).
2. The berth area adjacent to tanker and barge cargo tanks is to be Division 2 to the following extent:
 - a. 25 feet horizontally in all directions on the pier side from that portion of the hull containing cargo tanks.
 - b. From the water level to 25 feet above the cargo tanks at their highest position
3. Additional locations may have to be classified as required by the presence of other sources of flammable liquids on the berth, or by the Coast Guard or other regulations.

Appendix 3.2

The following diagrams illustrate the recommended construction of Acrylonitrile load and unload terminals for truck, rail, ISO tank, and marine. However, many other systems are in place and are equally suitable for safe and efficient Acrylonitrile handling.

Abbreviations

- CD = Chemical drain
- LI = Level indicator
- TI = Temperature indicator
- LAH = Level alarm high
- S/D = Shut down
- O2 = Oxygen
- FO = Fail open

Figure A-2a: Acrylonitrile barge loading

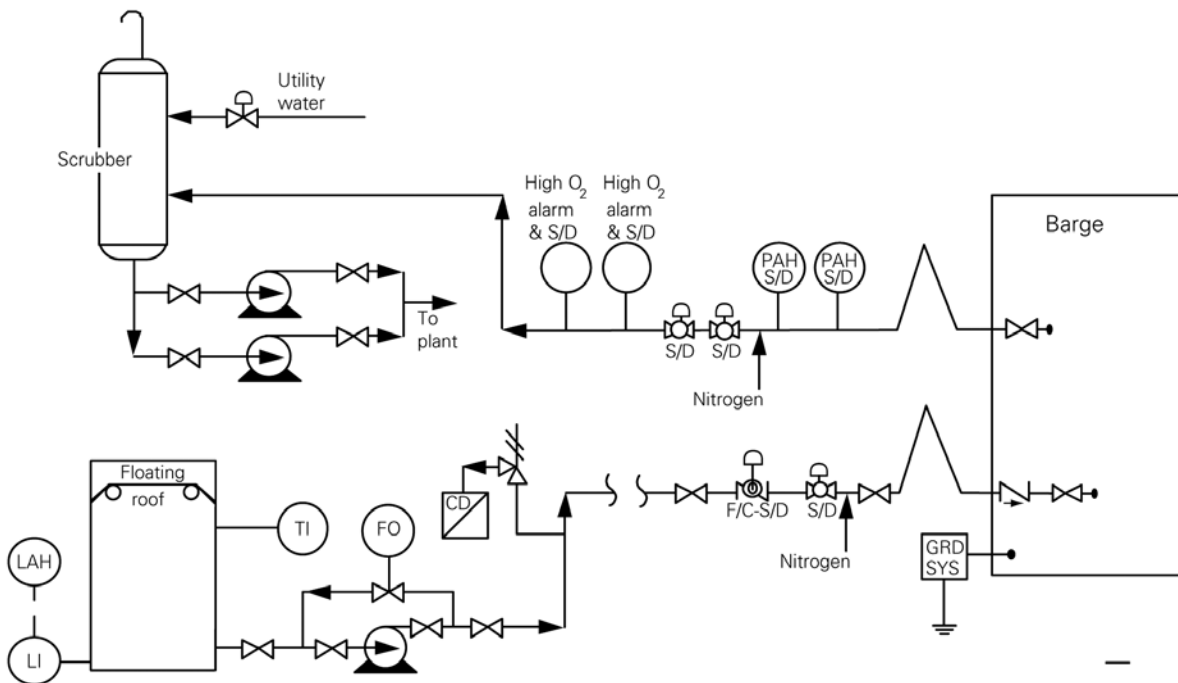

Figure A-2b: Acrylonitrile barge unloading

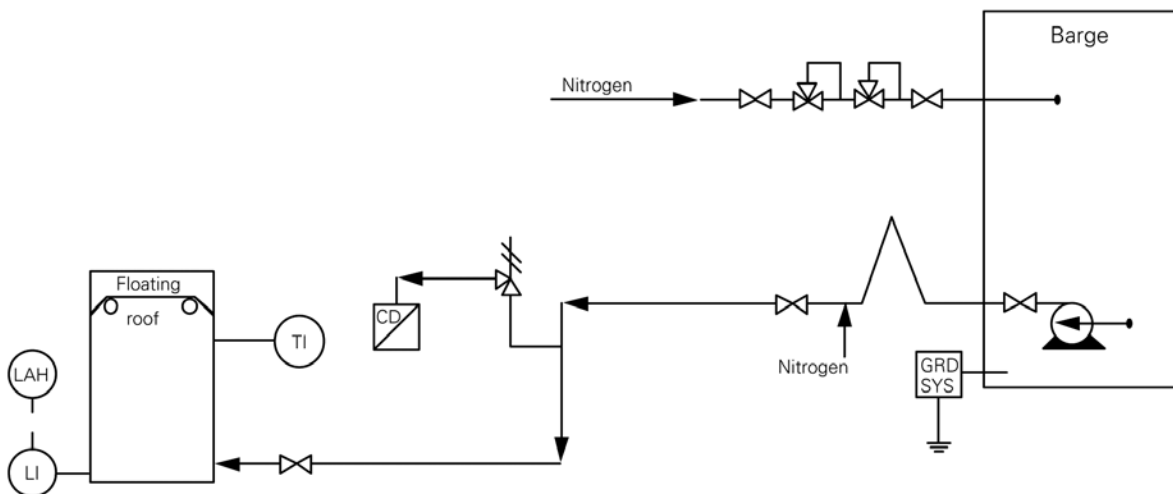

Figure A-2c: Acrylonitrile railcar loading

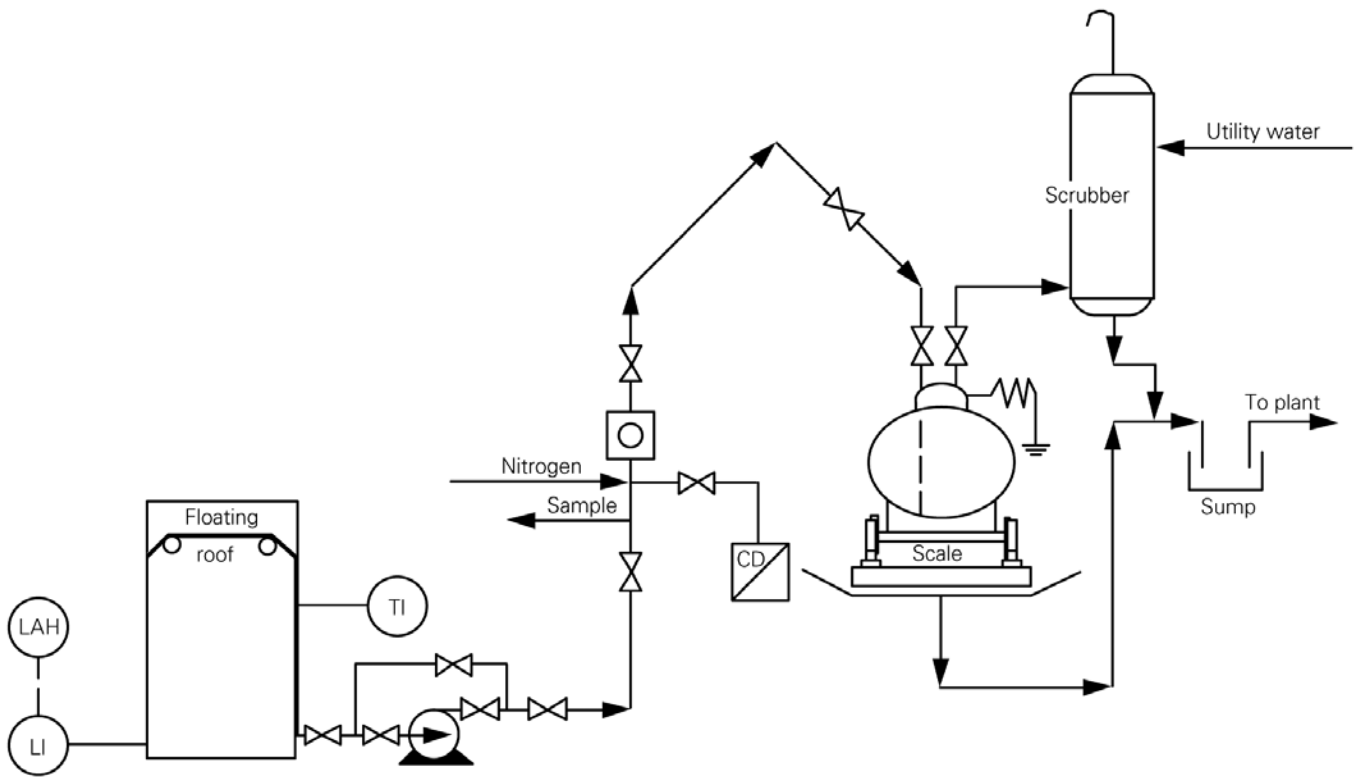

Figure A-2d: Acrylonitrile railcar unloading

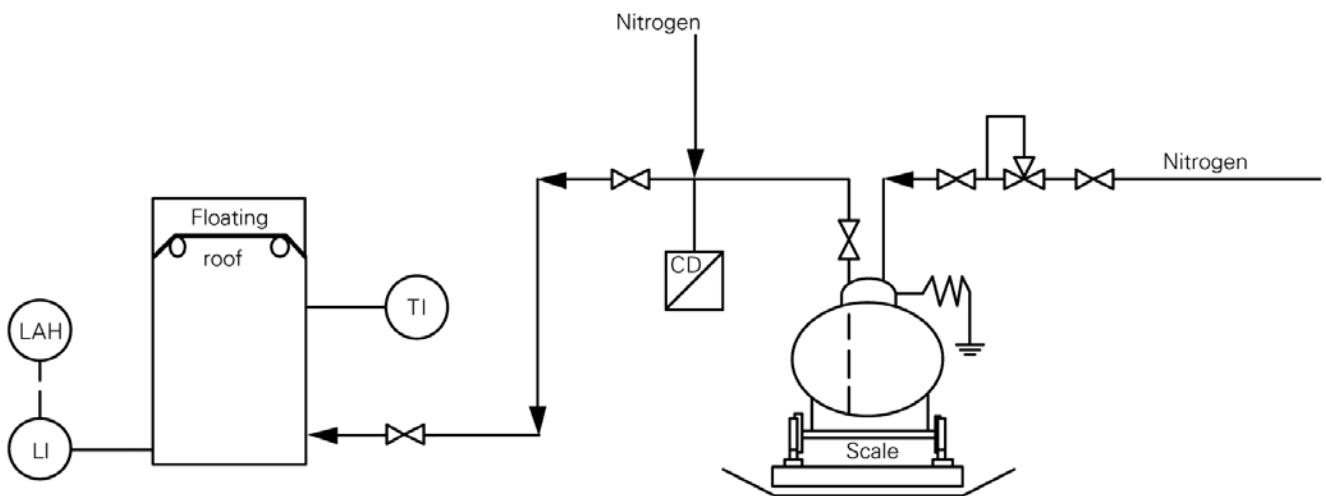

Figure A-2e: Acrylonitrile Iso-truck loading

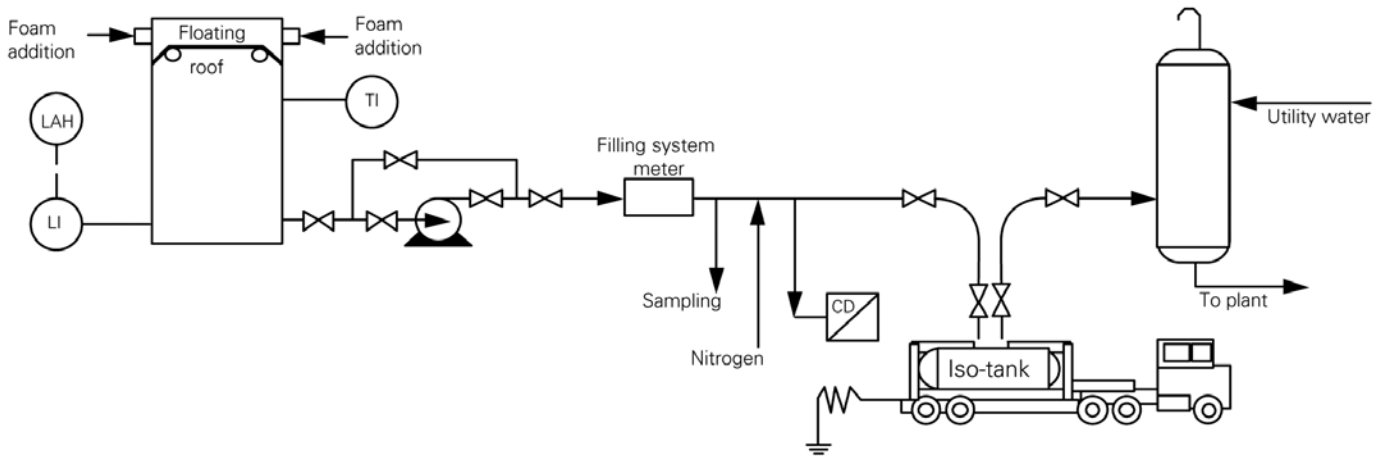

Figure A-2f: Acrylonitrile Iso-truck unloading

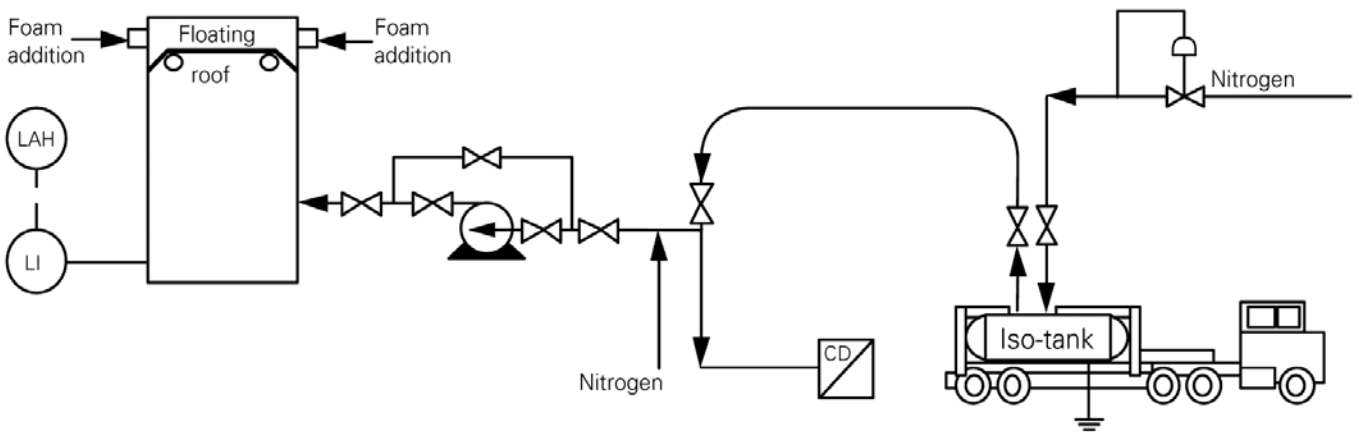

Figure A-2g: Acrylonitrile truck loading

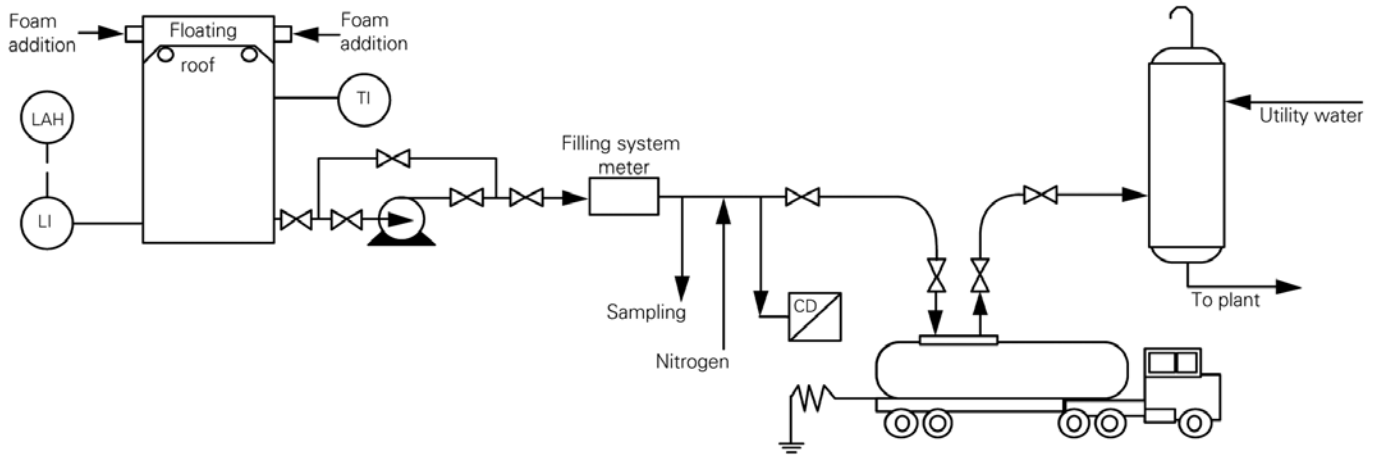
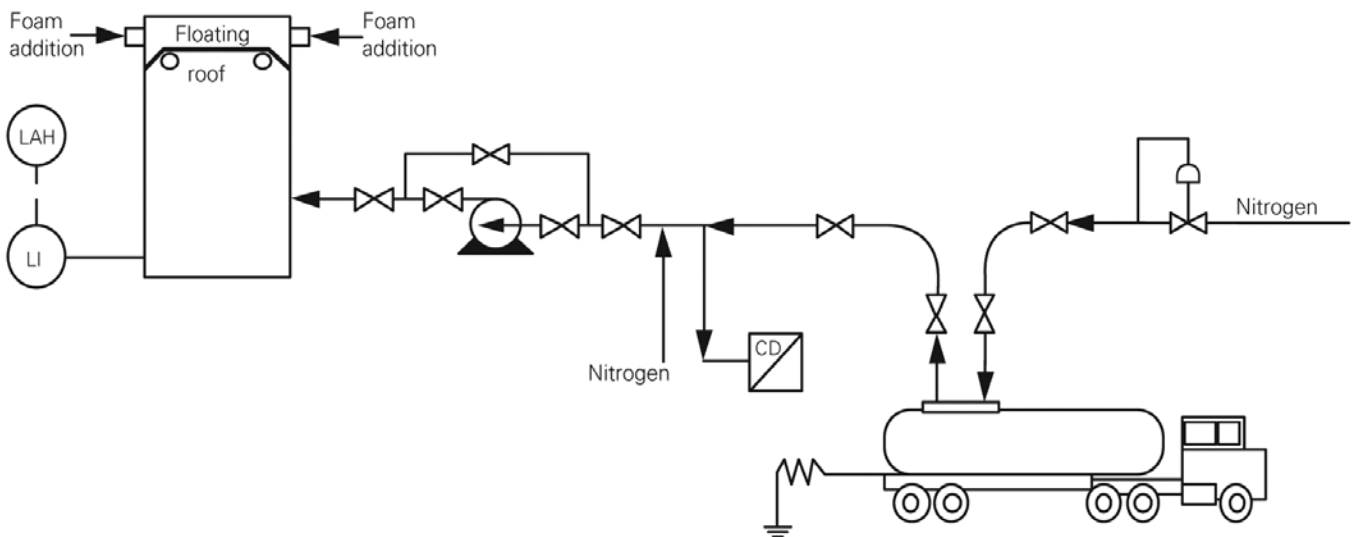

Figure A-2h: Acrylonitrile truck unloading



Section 4: Transfer and Transport

Equipment and procedures for transfer and transport of Acrylonitrile will vary widely depending on prevailing national and local operating regulations. However, some basic principles of safe handling apply regardless of a facility's location.

General Safety for Transfer and Transport

Acrylonitrile is commonly transported via ISO tank container, bulk truck, rail car, drum, barge or ship. Product transfer facilities and transport equipment must be designed to eliminate or responsibly manage potential Acrylonitrile handling hazards. Facilities and equipment must be diligently maintained and properly used.

Transport equipment should meet the requirements of state, federal and international regulations and may be subject to periodic inspection and testing under those regulations. Recognized authorities may perform inspections and testing in the facility's region.

Written operating instructions should be available at all transfer points, covering the applicable procedures for Acrylonitrile transfer. Personnel at all filling points must be fully trained in the implementation of the instructions. Both routine and emergency transfer situations should be covered in the written instructions.

An inspection check list is recommended for evaluating the condition of Acrylonitrile transport equipment. The evaluation should be performed before, during and after transfer.

All necessary protective clothing and emergency equipment should be readily available at all key areas of the transfer operation. Personnel should be thoroughly trained in the use of this clothing and equipment. (See Section 6)

Static electricity may build up during the loading or unloading of any Acrylonitrile transport mode. An approved grounding connection should be used during loading and unloading, and the grounding system should be checked periodically.

"Nitrogen blanketing" substantially reduces the potential for flammability of vapors above the surface of liquid Acrylonitrile. Nitrogen blanketing is used in closed cargo transfer handling systems during loading and unloading of truck, rail car or marine transport equipment. See Section 3 for further explanation of nitrogen blanketing.

Transfer of Acrylonitrile at a customer's facility is the customer's responsibility. Technical and safety information is available from INEOS.

Marine Safety

All barges and ships should be approved for cargo transfer based on a recognized standard of marine safety.

A ship/shore check list, or "Declaration of Inspection" should be completed to confirm that the vessel and the terminal have compatible equipment for the safe transfer of Acrylonitrile.

All cargo lines used in the loading and unloading operation should be pressure tested with nitrogen for confirmation of a contained, closed system and its integrity. This testing should be witnessed by a terminal representative, an approved cargo surveyor or a INEOS representative.

Nitrogen blanketing of a ship's cargo tanks is not required under international regulations. However, nitrogen blanketing is recommended for some transfer situations. Certain storage terminals are equipped with vapor control balance systems. Vessels transferring Acrylonitrile to such terminals should be nitrogen blanketed to reduce the oxygen level to less than 8 percent. Also, all barge cargo tanks should be nitrogen blanketed.

If flaring of loading vapors is considered, take extra precautions to prevent flashback and other hazards.

Truck and Rail Safety

Routine inspections should be performed before each load of Acrylonitrile is loaded into an ISO tank container, bulk truck or rail car.

All new truck/rail transport equipment should be inspected by a recognized professional prior to initial loading. Likewise, all transport equipment should be inspected prior to loading after service, maintenance, or repair.

Truck and rail transport equipment should be nitrogen blanketed at a pressure of 1-3 psi.

Drum Safety

Acrylonitrile arriving in drums should not be unloaded until the delivery vehicle is in its final unloading position – with all appropriate braking precautions in place.

Leaving vehicle doors open for several minutes will allow for ventilation before unload personnel enter a cargo area containing drums of Acrylonitrile.

Prior to unloading, the driver should inspect the drums for leakage. If a leak is found, all unload personnel should leave the area and report the leak to the facility's authorities. The shipper should also be notified of the leak.

Unload drums with appropriate equipment, such as a fork lift.

Store the drums where they can be protected against potential sources of puncture.

Once emptied of Acrylonitrile, dispose of drums in a safe, environmentally responsible manner. At a minimum, drums should be emptied of all product and rinsed three times with water. The rinse water should then be drained into a suitable water treatment system.

Section 5: Fire Safety

Fire-Related Chemical Properties

Acrylonitrile is a flammable liquid requiring safe handling to avoid fire or explosion. The chemical must not contact an open flame. At room temperature, Acrylonitrile vapors combined with air form flammable or explosive mixtures. See Table 5.1 for Acrylonitrile flammability values. Acrylonitrile vapors are heavier than air and may travel considerable distances or settle in low-lying areas. Acrylonitrile vapors may explode in the presence of a source of ignition. Ignited vapors also have the potential to “flash back” to the origin of the vapor, creating another fire hazard at the source.

Prevention

The most effective way of preventing an Acrylonitrile fire is to keep Acrylonitrile vapors contained or keep them from a source of ignition. Vapor emissions should be controlled, and monitoring for accidental vapor releases should be performed to guard against possible ignition. In addition to open flames, other sources of ignition (electricity, static, etc.) should be eliminated in areas generating unavoidable vapors, or where accidental vapor releases are highly probable. All mechanical equipment used near Acrylonitrile storage and handling areas must be designed for low flammability (i.e., intrinsically safe). Also, fire fighting equipment, sufficient for the maximum incident potential, should be readily at hand in these areas.

Extinguishment

Acrylonitrile fires may be extinguished with:

- Foam AFFF - (aqueous film forming foam) that is alcohol resistant is recommended for extinguishing polar solvents such as Acrylonitrile. Protein and other foams may be ineffective.
- Dry chemical - potassium bicarbonate-based dry chemical
- Carbon dioxide/Halon® - substitute

Water alone is ineffective as an extinguishing agent, however, it may be used to cool fire-exposed containers, to disperse vapors, to protect personnel or to flush spill away from sources of ignition.

Exposed firefighters should wear approved self-contained breathing apparatus with full face mask in the positive pressure mode, and full protective equipment. For advanced or massive fire, fire fighting should be done from a safe distance or protected location.

Care must be exercised in determining sufficient fire fighting ability when confronting an incident. The potential for a small fire to increase rapidly into a major fire should be anticipated. A single fire fighter should immediately notify other emergency response personnel who will be ready to assist if the fire increases.

Decomposition Products

Burning Acrylonitrile may produce toxic gases such as hydrogen cyanide, nitrogen dioxide or carbon monoxide. Emergency response personnel, as well as the surrounding population, must be protected against exposure to these gases. Evacuation procedures should be in place in all work and public areas adjacent to Acrylonitrile storage and handling facilities. Run-off from fighting an Acrylonitrile fire should be contained to prevent harm to the surrounding public and environment.

Table 5.1: Acrylonitrile Flammability Values

Flash point, °C (°F)	0 (32)
Autoignition temperature, °C (°F)	481.1 (898)
Lower flammability limit, %	>3.0
Upper flammability limit, %	<17.0

Section 6: Occupational Safety and Health

Occupational exposure to Acrylonitrile is governed by regulations and guidelines established to protect employees from potentially harmful chemical effects. Many countries have determined reasonable occupational exposure limits for Acrylonitrile.

For a partial list of these limits, see Table 6.1 – Sample of Acrylonitrile occupational exposure limits.

United States Exposure Limits

In the United States, three organizations have developed limits for exposure to Acrylonitrile. These limits should be used as a guide in assessing and controlling work-related exposures.

OSHA-PEL

The Occupational Safety and Health Administration (OSHA) has developed a standard for regulation of Acrylonitrile. The OSHA standard regulates Acrylonitrile as a carcinogen. This standard states that employers with workers handling Acrylonitrile are to ensure that:

- No employee is exposed to an airborne concentration of Acrylonitrile in excess of two (2) parts of Acrylonitrile per one (1) million parts of air, or 2 ppm, during an eight (8) hour, time-weighted average – the Permissible Exposure Limit (PEL)
- No employee is exposed to an airborne concentration of Acrylonitrile in excess of ten (10) ppm as averaged over any fifteen (15) minute period during the work day – the Ceiling Limit
- No employee is exposed to skin or eye contact with liquid Acrylonitrile

Acrylonitrile vapors can affect the body if they come in contact with the skin or the eyes, or if they are inhaled or swallowed. Therefore, the maximum concentration of Acrylonitrile exposure allowed over an eight (8) hour workday is 2 ppm.

Acrylonitrile odor cannot consistently be detected below its odor threshold of 13-20 ppm, which is 7 to 10 times higher than the 2 ppm PEL. The odor threshold is also above the 10 ppm Ceiling Limit. Therefore, when an Acrylonitrile

Table 6.1: Sample of Acrylonitrile occupational exposure limits

Country	Time-Weighted Average (TWA) (usually 8 hours)	Short Term Exposure Limit (STEL) (usually 15 minutes)
Australia	2 ppm; Category 2 Probable human carcinogen, Skin.	-
France	2 ppm (4.5 mg/m ³)	15 ppm (32.5 mg/m ³)
Germany	3 ppm (TRK); A2 carcinogen, unmistakably carcinogenic in animal experimentation only, Skin	
Hungary	-	2 ppm, Ceiling
Japan	2 ppm; Skin	-
Russia	0.5 mg/m ³	1.5 mg/m ³ Ceiling
Sweden	2 ppm	6 ppm; Carcinogen; Skin
United Kingdom	2 ppm; Skin	-
United States (complete explanation follows)	OSHA-PEL – 2 ppm; Action Level – 1 ppm; Skin.	10 ppm, Ceiling
	NIOSH-REL –1 ppm; Ca – occupational carcinogen, Skin.	10 ppm, Ceiling; IDLH – 85 ppm (Immediately Dangerous to Life or Health)
	ACGIH-TLV – 2 ppm	Not specified
	A3 – confirmed animal carcinogen with unknown relevance to humans; Skin	

1 ppm acrylonitrile in air by volume = 2.17 mg/m³ (25°C)

odor is detected, anyone exposed to it must move into fresh air immediately. Acrylonitrile exposure levels above 2 ppm and skin or eye contact with the chemical must be prevented. To do so, appropriate controls must be placed – engineering controls, such as revision in process design; additional ventilation; administrative controls such as worker rotation; and approved worker safety controls, such as personal protective equipment.

NIOSH-REL

The National Institute for Occupational Safety and Health (NIOSH) has developed a Recommended Exposure Limit (REL) of one (1) ppm as an eight (8) hour time-weighted average and a fifteen (15) minute ceiling of ten (10) ppm. In addition, NIOSH has determined that 85 ppm is the Immediately Dangerous to Life and Health (IDLH) value for Acrylonitrile in air. NIOSH has also designated the chemical as an occupational carcinogen.

ACGIH-TLV

The American Conference of Governmental Industrial Hygienists (ACGIH) has established 2 ppm as the Threshold Limit Value (TLV) for an eight (8) hour time-weighted average. ACGIH previously designated Acrylonitrile as a suspected human carcinogen.

The International Agency for Research on Cancer (IARC) recently downgraded Acrylonitrile from a “probable” to a “possible” human carcinogen. With this new IARC rating, ACGIH reduced the rating for Acrylonitrile from A2 – suspected human carcinogen to A3 – confirmed animal carcinogen with unknown relevance to humans; Skin.

Selecting Acceptable Exposure Limits

Facilities selecting and applying acceptable Acrylonitrile exposure limits should consult any prevailing government standards, which should be met as a minimum. Limits for short-term exposure should also be applied where acceptable exposure limits are likely to be exceeded for tasks of short duration, usually 15 minutes or less.

Monitoring for Acrylonitrile Exposure Levels

Airborne concentrations of Acrylonitrile in the workplace can be measured using direct reading instruments, such as the detector tube, or with instruments that monitor throughout a workday, such as the personal sampling pump and charcoal tube or passive diffusion badge.

Monitoring to evaluate a worker’s eight (8) hour exposure potential is performed using NIOSH Method 1604, issue 2 dated August 15, 1994. To perform this method,

Table 6.2: Monitoring requirements

Action Level = 1 ppm (in the United States)
 Permissible Exposure Limit = 2 ppm (in the United States)

Monitor results	Monitoring frequency
Below the Action Level	Monitoring may be discontinued for that employee.*
At or below the Action Level, but below the Permissible Exposure Limit	Repeat monitoring at least every six months until 2 consecutive measurements taken 7 days apart, are below the Action Level. Hereafter, monitoring may be discontinued for that employee.*
Above the Permissible Exposure Limit	Repeat monitoring at least quarterly until 2 consecutive measurements taken 7 days apart reveal exposure below the permissible limit. After reducing exposure to below the Permissible Exposure Limit, monitoring may be repeated every six months.

*Additional monitoring must be performed whenever there are changes in the production process, control or personnel. Also, non-routine activities such as a periodic maintenance procedure may require more frequent or additional monitoring.

Acrylonitrile vapor is collected on charcoal sorbent tubes. The collected vapor is then desorbed by solvent or thermal means and the amount of Acrylonitrile present is determined by gas chromatography utilizing a flame ionization detector. Details of this method are available on the internet (<http://www.cdc.gov/niosh/nmam/pdfs/1604.pdf>).

The frequency of routine monitoring is determined with the results of initial exposure monitoring. See Table 6.2 - Monitoring requirements for frequency guidelines.

Regardless of the monitoring method used, the results must be at a confidence level of 95 percent. The confidence level must be accurate within plus or minus 35 percent for concentrations at or above the acceptable exposure limit, or within plus or minus 50 percent for concentrations below the acceptable exposure limit. See OSHA standard 29 CFR 1910.1045 Appendix D for additional details, available on the internet (http://www.osha.gov/pls/oshaweb/owadisp.show_document?p_table=STANDARD&p_id=10069&p_text_version=FALSE).

Personal Protective Equipment

When effective engineering controls are not feasible, or while they are being instituted, respiratory protection may be used to reduce employee Acrylonitrile exposure to within appropriate occupational exposure limits.

Circumstances Requiring Respirator Use

See Table 6.3 - Acrylonitrile respiratory protection for recommended respirator types at varying exposure levels.

Respiratory protection should be used in the following circumstances:

- during the installation of engineering controls
- during maintenance and repair activities
- during reactor cleaning where use of engineering controls is not feasible

Table 6.3: Acrylonitrile respiratory protection

Concentration of Acrylonitrile or condition of use	Type of respiratory protection
Less than or equal to 20 ppm	Chemical cartridge respirator* with organic vapor cartridges and half-mask face piece (or full face piece), or Supplied air respirator with half-mask face piece.
Less than or equal to 85 ppm or Maximum Use Concentration (MUC) of cartridges or canisters, whichever is lower	Full face piece respirator* with a) organic vapor cartridges, or b) organic vapor gas mask, chin style, or c) organic vapor gas mask canister, front or back mounted. Supplied air respirator with full face piece, or Self-contained breathing apparatus with full face piece.
Less than or equal 1000 ppm	Supplied air respirator operated in the positive mode with full face piece, helmet, suite or hood
Greater than 1000 ppm or unknown concentration	Supplied air and auxiliary self-contained breathing apparatus with full face piece in positive pressure mode; or Self-contained breathing apparatus with full face piece in positive pressure mode
Fire fighting	Self-contained breathing apparatus with full face piece in positive pressure mode.
Escape	Any organic vapor respirator*, or any appropriate escape type self-contained breathing apparatus

*NOTE: Cartridge and canister respirators are not to be used in atmospheres containing less than 19.5% oxygen.

- when available engineering controls are not sufficient to reduce exposure below appropriate occupational exposure limits
- during emergencies
- in any situation where monitoring finds Acrylonitrile vapor concentrations above 2 ppm

Monitoring should always be performed in Acrylonitrile handling situations to establish the proper level of personal protective equipment required.

Employee Training

Employers must provide respirators to employees working in areas where exposure is likely to reach or exceed the appropriate occupational exposure limit. Employees should be trained in the use and necessity of respirators. Employers must provide necessary respirators at no cost to the employee.

Employee training should include instruction and “hands on” use of the respirator – including proper fit and adjustment; the impact of glasses or facial hair on maintaining a tight seal; and, the need for periodic testing of equipment to ensure continued protection. Site-specific training should also be conducted to alert employees to the various areas of the facility where protection is mandatory. Instruction should also include training on the proper selection and limitations of respiratory protection. All employees should be given a medical examination to determine whether each is physically able to perform the required work while wearing a respirator. Employee medical status should be reviewed annually.

The use of respirators in Acrylonitrile operations must comply with a written respiratory protection procedure – including a list of specific respirators that must be worn at specific workstations, and when each respirator must be worn. The procedure must also instruct employee to:

- inspect the face piece to ensure a proper fit before each use
- label the cartridge with the date and time of installation
- discard the cartridge at the end of each shift
- keep the respirator securely sealed at all times in the work area

Employers should periodically confirm that proper procedures for respirator use are consistently followed by all employees.

Respiratory Protection Selection

All respirators used in Acrylonitrile operations must be designed specifically for use with Acrylonitrile. In the United States, selection of a suitable respirator should be made from those approved by NIOSH. Specific selection criteria include:

- information on general conditions of use
- physical, chemical and toxicological properties of Acrylonitrile
- odor threshold data
- NIOSH recommended exposure limit
- OSHA permissible exposure limit
- IDLH value
- eye irritation potential
- service life for canisters and cartridges

Respirators should be tested and service performed on a regular basis. Inspection and replacement of worn or deteriorated parts must be performed regularly, as well as regular cleaning and disinfecting. All respirator equipment should be stored in a clean, sanitary location.

Human Toxicity Precaution

Acrylonitrile is toxic by all routes of exposure. Direct contact with Acrylonitrile can also cause chemical skin burns or blisters.

Acrylonitrile liquid and vapor are readily absorbed into shoe leather and clothing, and will penetrate most rubbers, barrier fabrics or creams.

Impermeable protective clothing must be used by all employees who work in locations where Acrylonitrile is likely to come in contact with the eyes or the skin. It must also be ensured that employees wear the appropriate protective clothing in all applicable Acrylonitrile work locations.

Impermeable protective clothing includes butyl rubber gloves, chemical boots and suits, and splash-proof safety goggles or face shields. These items, and other Acrylonitrile protective clothing, must be made from materials specifically recommended for protection against Acrylonitrile penetration. Also, the duration of the job task, the thickness of the protective clothing material, and the “break-through time” must also be considered in selecting appropriate protective wear. Breakthrough time is the amount of time the material will keep out Acrylonitrile liquid before penetration and resultant skin contact takes place (See Table 6.4 - Impervious materials data for Acrylonitrile protection).

Other considerations in selecting the proper materials should include the effects of temperature, pressure and the need for flexibility.

Table 6.4: Impervious materials data for Acrylonitrile Protection

Material	Breakthrough (minutes)
Butyl rubber	>480
Neoprene	20
Polyvinyl alcohol	42
DuPont Tychem® SL	50
DuPont CPF®4	377
DuPont Responder®	>480
Siebe North Silver Shield®	>480

Although this information provides a general overview of protection factors for various types of chemical protective clothing, specific data and use limitations from protective clothing manufacturers should be consulted prior to selection.

Section 7: Medical Response and First Aid

This section is designed to assist non-medical personnel in treating individuals exposed to Acrylonitrile. Qualified medical personnel should be consulted as soon as possible after exposure to Acrylonitrile.

Exposure to Acrylonitrile can occur through contact with the skin or eyes, swallowing or inhaling. Exposure at certain concentrations can produce serious acute (short term) toxicity. The health effects of acute exposure can, however, be reversed through decontamination and appropriate first aid. Length of exposure and concentration, particularly of vapors in air, will determine the consequences of exposure to Acrylonitrile. For long-term health effects, see “Chronic Health Effects,” below.

Signs and Symptoms of Exposure

Short term overexposure to Acrylonitrile vapors causes eye irritation, headache, throat and mucous membranes irritation, nausea, vomiting, weakness and lightheadedness. Prolonged or repeated exposure to the skin can produce skin irritation, severe dermatitis or latent formation of large vesicle (resembling second degree burns). High concentrations could lead to loss of consciousness or death if emergency first aid is not administered. Toxic effects of acute Acrylonitrile exposure may be delayed from a few minutes to several hours. All chemical handling facilities should be equipped with “quick drenching” stations, including emergency eye wash stations and showers. These stations must be located for easy access to all personnel throughout the plant. Employees must be trained in the use of this equipment, and the equipment must be regularly inspected and maintained.

Emergency First Aid

Call for assistance immediately, and begin treatment for the following...

- **Eye Contact** – Thoroughly flush the eyes with flowing water for a minimum of 15 minutes. Occasionally lift the upper eyelids for thorough flushing. If irritation, pain, swelling, watery eyes or light sensitivity persists after 15 minutes, seek qualified medical follow-up. Also see treatment for inhalation, in next column.
- **Skin Contact** – Thoroughly rinse the affected area with flowing water, and, when available, use a mild soap or detergent. The underlying skin should be rinsed and washed as instructed above for a minimum of 15 minutes. If symptoms occur after washing, seek qualified medical attention. Also see treatment for inhalation below.

Prolonged skin contact or inadequate decontamination may cause inflammation of vesicles resembling a second degree burn. Any clothing soaked with Acrylonitrile should be removed immediately. Enclose contaminated articles in a plastic bag to prevent further exposure.

Before reuse, contaminated clothing must be washed in an appropriate hazardous waste contaminant laundry system. Contaminated leather shoes, belts, wallets or clothing must be discarded.

- **Inhalation** – If breathing has stopped and Acrylonitrile was not ingested, perform mouth-to-mask resuscitation. Exposed individuals, must be taken to fresh air immediately, decontaminated and administered 100% oxygen through a positive pressure oxygen resuscitator. If breathing and pulse are not detected, perform cardiopulmonary resuscitation. If consciousness is impaired or decreasing, the individual must be treated aggressively for acrylonitrile and cyanide poisoning by trained rescue or medical personnel.
- **Ingestion** – If Acrylonitrile is swallowed, DO NOT induce vomiting. Treat as described under Inhalation.

Rescue of the Unconscious

In addition to the steps for specific exposure listed above, rescue personnel must remove the unconscious individual from the contaminated area, remove any Acrylonitrile-contaminated clothing, decontaminate and keep the individual warm, and transport him or her to the hospital as soon as possible.

Chronic Health Effects

In 1998, the National Cancer Institute (NCI) and the National Institute of Occupational Safety and Health (NIOSH) published the final results of an extensive epidemiology study of Acrylonitrile workers. The study included 25,000 workers at eight U.S. plants that either made Acrylonitrile or used it in making other products.

These workers, employed from the 1950s through 1983, were followed through 1989. The study had the following results:

1. Death rates from all causes combined were 30 percent lower among Acrylonitrile workers than the general population;
2. Cancer mortality rates from all causes combined were also lower than the general population and lower than an internal comparison group of workers not exposed to Acrylonitrile; and
3. Mortality from lung cancer among Acrylonitrile workers was lower than the U.S. rates.

Acrylonitrile exposure has been found to cause cancer in laboratory animals – through ingestion and inhalation. In 1998, the International Agency for Research on Cancer (IARC) lowered the cancer classification for Acrylonitrile from limited evidence of a cancer hazard in humans to inadequate evidence of a cancer hazard in humans and sufficient evidence in experimental animals. According to the United States National Toxicology Program (NTP) only limited evidence of a cancer hazard exists for humans.

For further information on the health effects of Acrylonitrile, please refer to the most recent INEOS Material Safety Data Sheet (MSDS).

Section 8: Emergency Response and Environmental Protection

Emergency response to an unplanned release of Acrylonitrile may never occur if the chemical is stored and handled properly at all times. However, as with all hazardous substances, accidents are always possible. Therefore, sufficient emergency response capability is a necessity for responsible management of a hazardous chemical facility.

The preparation conducted before an emergency occurs is the most important part of an effective emergency response plan. All facilities should develop a thorough plan covering all possible consequences of an Acrylonitrile emergency, including problems that might be specific to a particular site. Emergency response plans should be tested through periodic drills that involve all emergency response personnel, both on-site and in the local community.

Note: This section is only a summary of the steps needed to execute an effective emergency response to an Acrylonitrile release. See other sections of this booklet for fire fighting procedures and emergency medical response.

Definition of Emergency

An “emergency” is any occurrence resulting in the unexpected, significant release of Acrylonitrile. In an Acrylonitrile “emergency,” loss of containment has occurred and must be stopped in order to protect employees, the public and/or the surrounding environment.

An incident confined to a limited area, which can be handled by on-site, trained personnel using proper protective clothing and equipment, is not considered an emergency situation. Non-emergency situations can include malfunctioning pumps, defective lines or leaking valves or seals. Also, small spills may occur but can generally be handled without alarm.

Initial Response Activities

All chemical facilities should be equipped with a plant wide emergency notification system or alarm.

Emergency response personnel should determine the need for respiratory protection, (primary) exposure monitoring, evacuation procedures and other immediate activities.

The emergency area, or “hot zone,” must be surrounded and sufficiently barricaded in order to control access and to prevent inadvertent exposure to the chemical.

Acrylonitrile vapors are heavier than air and travel along the ground. Any spark or flame could ignite the vapors and could cause a “flash back” to the source of the release. Flash backs have the potential for causing explosion.

With the accidental release of any flammable substance, including Acrylonitrile, all “hot work” such as welding and vehicular traffic in the area must be stopped immediately.

All reasonable efforts must be made to stop the flow of Acrylonitrile into the emergency situation, such as closing valves or shutting off pumps and electrical circuit breakers.

Evacuation

The area surrounding an Acrylonitrile emergency should be evacuated immediately. The scope of the evacuation should be determined by the size of the spill, the wind direction, and whether or not a loss of containment can be stopped.

“Shelter in place” is the best response in certain circumstances. However, this determination must only be made by experienced professionals, such as community emergency response crews or fire fighters in hazardous materials response.

Communication

Local emergency response authorities should be immediately notified of an Acrylonitrile emergency. Consult local and national regulations for notification requirements. Many government agencies require immediate notification of specific agencies and reporting of estimated chemical quantities involved in the emergency.

In the United States, Acrylonitrile is listed as a CERCLA hazardous substance and EPCRA extremely hazardous substance with a Reportable Quantity (RQ) of 100 pounds (about 15 gallons). Releases of Acrylonitrile above the RQ are subject to the “immediate” reporting requirements contained in the regulations and includes notification of the National Response Center, the Local Emergency Planning Committee and the State Emergency Response Commission.

Emergency Rescue

The first response crew at the scene must wear, at a minimum, a self-contained breathing apparatus (SCBA) for respiratory protection and chemical protective clothing for skin protection against liquid or high vapor level contact. This protection must be maintained until air monitoring can determine the concentration of Acrylonitrile vapors which will assist in the determination of the appropriate protection.

Exposure readings should be taken by trained individuals at a safe distance from the source, preferably up wind. A reading of 85 ppm in air is considered immediately dangerous to life or health. A SCBA and a totally-encapsulating chemical protective suit are unconditionally required in concentrations of 85 ppm or more.

Decontamination

A suitable location must be selected for primary decontamination – safely cleaning of personnel, equipment and supplies after exposure. This is one of the most important steps in assuring personal safety during and immediately after an emergency.

The entry point to the decontamination area should be clearly marked. Persons leaving the “hot zone” should immediately pass through a shower, proceeding to decontaminate using soap and water. Any contaminated equipment should be decontaminated if possible. Contaminated equipment that cannot be decontaminated should be left in the area and properly disposed of. Run off water should be directed to a safe area for treatment and disposal.

Environmental Protection

A release of Acrylonitrile can severely impact the environment if not properly managed. Therefore, safeguards must be in place throughout the Acrylonitrile production and handling process to prevent or minimize release of the chemical to the environment. These include processes engineered to minimize emissions, properly designed pollution control equipment and handling procedures developed to anticipate and prevent releases to the environment. Nonetheless, emergency response plans should be developed to mitigate the environmental impact from a release of Acrylonitrile.

Environmental Regulation

Most countries regulate the production, handling, storage and release and disposal of Acrylonitrile and its byproducts through comprehensive environmental laws or standards. However, Acrylonitrile production and handling facilities outside of the United States may be regulated much differently than those within the U.S. It is always prudent to consult with local, regional and national regulatory authorities regarding the applicable environmental standards for an Acrylonitrile production or handling facility. Generally, environmental requirements and industry standards can be obtained from industry and trade associations. INEOS's Health, Safety and Environment Group can also provide assistance with regulatory compliance issues.

Regulatory Information

The product and uses described herein may require product registrations and notifications for chemical inventory listings, or for specific uses (e.g. related to foods, drugs, pesticides, medical devices).

Health and Safety Information

The product described herein may require precautions in handling and use because of toxicity, flammability or other consideration. The available product health and safety information for this material is contained in the Material Safety Data Sheet (MSDS) that may be obtained by calling +1-866-363-2454 (Toll Free-North America). Before using any material, a customer is advised to consult the MSDS for the product under consideration for use.

The Material Safety Data Sheet for this product contains shipping descriptions and should be consulted, before transportation, as a reference in determining the proper shipping description. If the material shipped by INEOS is altered or modified, different shipping descriptions may apply and the MSDS of the original material should not be used.

For additional information, on samples, pricing and availability, please contact:

INEOS USA LLC
Customer Service
2600 South Shore Blvd.
League City, Texas
Toll-free: 866-363-2454
Fax: 866-398-8807

Technical information contained herein is furnished without charge or obligation, and is given and accepted at recipient's sole risk. Because conditions of use may vary and are beyond our control, INEOS makes no representation about, and is not responsible or liable for the accuracy or reliability of data, nor for toxicological effects or Industrial Hygiene requirements associated with particular uses of any product described herein. Nothing contained in this document shall be considered a recommendation for any use that may infringe patent rights, or an endorsement of any particular material, equipment, service, or other item not supplied by INEOS. The "Properties" and "Applications" listed in this document are not specifications. They are provided as information only and in no way modify, amend, enlarge, or create any specification or warranty, and ALL WARRANTIES, EXPRESS OR IMPLIED, INCLUDING WITHOUT LIMITATION THE WARRANTIES OF MERCHANTABILITY AND FITNESS FOR A PARTICULAR PURPOSE, ARE EXCLUDED.

